

VOLCLAY

WATER STOP-RX[®]

EXPANDING CONCRETE JOINT WATERSTOP

Wall



Slab



Penetration



CETCO[®]

WATERSTOP-RX® is an expanding strip waterstop designed to stop water infiltration through cast-in-place concrete construction joints. It expands upon contact with water to form a positive seal against the concrete. The key to WATERSTOP-RX's effectiveness is high sodium bentonite content which provides superior expansion to seal and fill voids and cracks in the concrete. WATERSTOP-RX is designed to replace passive PVC/Rubber dumbbell waterstops, thereby eliminating the requirement of special pieces, split-forming and seam welding. Specified worldwide, WATERSTOP-RX has a 25-year proven track record as a reliable and cost-effective solution for stopping water ingress through concrete joints.

WATERSTOP-RX is manufactured in light-weight, flexible coils that are easily installed by a single worker. The product is adhered to concrete, steel, and PVC (pipes) with CETSEAL at or exceeding the required minimum distance from the exterior concrete surface. Coil ends are butted together – not overlapped – to form a continuous waterstop.

WATERSTOP-RX is available in three sizes and shapes (see Product Table on back page). WATERSTOP-RX 101 is produced in a rectangular shape measuring 1" x 3/4" (25 x 19mm). WATERSTOP-RX 101T is produced in a trapezoidal shape measuring 1-1/4" x 1/2" (31 x 12mm) with a reinforcing plastic scrim embedded in the top surface for high tensile strength. The patented trapezoidal shape distributes the expansive force over a greater area and allows the concrete to flow more readily over the product during placement. WATERSTOP-RX 102 is produced in a half-circle (Crescent) shape measuring 3/4" x 3/8" (19 x 9mm).



RX101



RX101T

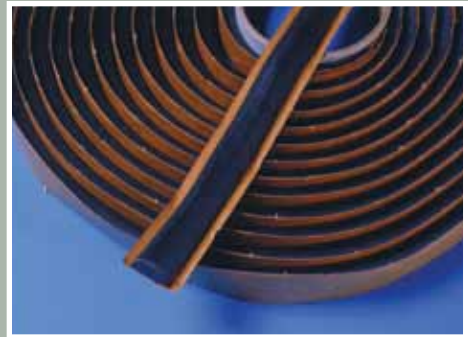

RX102

WATERSTOP-RX ADVANTAGES:

- Active, Swelling Waterstop
- Fast, Easy Installation
- Seals Around Penetrations
- Ideal when pouring against existing concrete
- Expands to seal off leaks
- High Hydrostatic Resistance

APPLICATIONS

Applications include both vertical and horizontal non-moving concrete construction joints, new to existing concrete construction, irregular surfaces, and around through-wall penetrations, such as plumbing and utility pipes. Additionally it can seal around concrete pilings and steel I-beams passing through the concrete. WATERSTOP-RX works in both continuous hydrostatic and intermittent hydrostatic conditions.

WATERSTOP-RX products are designed for reinforced structural concrete with a minimum of 3,000 psi compressive strength. RX-101 and RX-101T products are designed for concrete 8" (200mm) thick or greater with two rows of reinforcing steel. RX-102 products are designed for vertical concrete 5" (125mm) thick or greater; and horizontal concrete no less than 4" (100mm) thick. RX-102 products should be used in concrete with one row of steel reinforcement, concrete curbs, planter walls, fountains, and lightweight structural concrete.

WATERSTOP-RX
is an effective, simple and economical
material for cast-in-place concrete joints.

GENERAL APPLICATION DETAIL

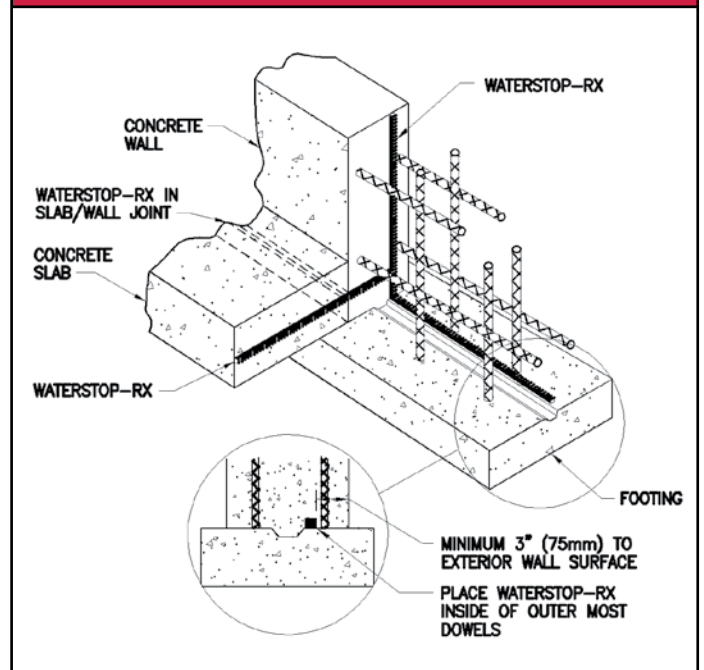

WATERSTOP-RX should only be used in applications where the product is completely encapsulated within the concrete at or exceeding 3" (75 mm) from the exterior concrete surface (2" (50 mm) for RX102). WATERSTOP-RX is not designed nor intended to function as an expansion joint sealant.

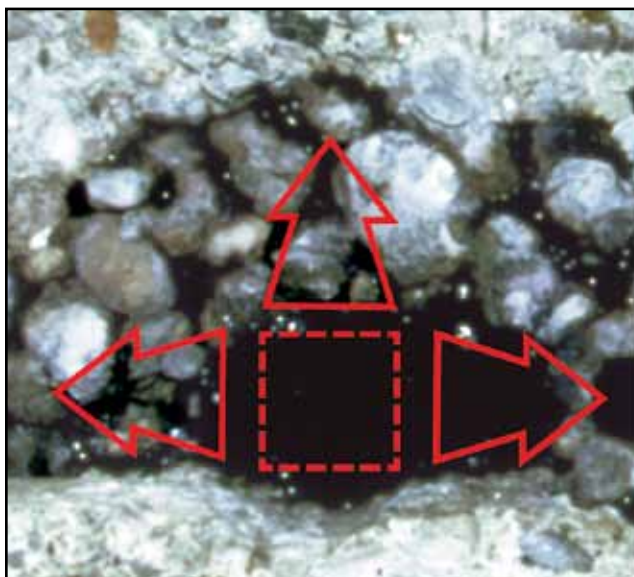

In poorly consolidated concrete, WATERSTOP-RX can expand to fill voids, stopping water ingress through the concrete joint.



When hydrated, WATERSTOP-RX can expand up to three times its size in an unconfined area but is limited to controlled expansion in a concrete joint where it is confined.



Unlike PVC waterstops, WATERSTOP-RX can easily be installed around irregular structural elements.

VOLCLAY WATERSTOP-RX®



RX 101 - 3/4" x 1"

Designed for vertical and horizontal concrete 8" thick or greater.



RX 101T - 1-1/4" x 1/2"

Reinforced trapezoidal designed for shotcrete, extreme hot weather and difficult applications.



RX 102 - 3/8" x 3/4"

Designed for vertical and horizontal concrete 5"-8" thick.

WATERSTOP-RX PRODUCT TABLE

PRODUCT	SIZE	SHAPE	LN FT/ CARTON
RX-101	1" x 3/4" x 16' 8"	Rectangle	100 lf. (30.4m)
RX-101T	1-1/4" x 1/2" x 20'	Trapezoid with Poly Scrim Reinforcement	120 lf. (36.5m)
RX-102	3/4" x 3/8" x 33' 4"	Half-Circle	200 lf. (61m)

TYPICAL PROPERTIES

PROPERTY	TEST METHOD	VALUE
Hydrostatic Head Resistance	Independent Test	231Ft. (70 m)
Wet/Dry Cycling (25 Cycles @231 ft)	Independent Test	No Effect
Adhesion to Concrete using CETSEAL	Independent Test	Excellent

ACCESSORY PRODUCTS

WATERSTOP-RX is not a self-adhering product. CETSEAL is required to secure WATERSTOP-RX to concrete, metal, or PVC (pipe) surfaces. Mechanical fasteners should not be used to secure WATERSTOP-RX alone but may be used in conjunction with adhesive.

CETSEAL

CETSEAL is a multi-purpose, single component polyether moisture cure sealant/adhesive. CETSEAL is a low VOC, 100% solids, non-shrinking product with excellent UV resistance..

June 2010 (Supersedes All Previous Versions)

The information contained herein supersedes all previous versions, and is believed to be accurate and reliable. CETCO makes no warranty of any kind and accepts no responsibility for the results obtained through application of this information. CETCO reserves the right to update information without notice.

www.cetco.com

PH 800.527.9948 or 847.851.1800

2870 Forbs Avenue • Hoffman Estates, IL 60192

© 2010 CETCO Printed in the U.S.A. June 2010 - WRX-001